

PiezoDrive

PDm200

High Performance Piezo Driver

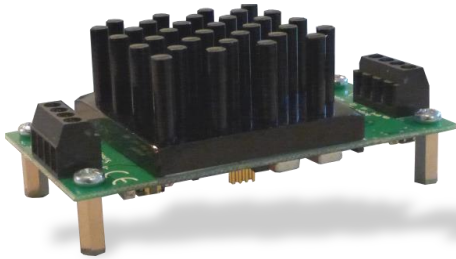

The PDm200 is a complete high-performance power supply and linear amplifier module for driving piezoelectric actuators. The output voltage range can be switched between bipolar or unipolar modes with a range of 100V, 150V, or 200V. Up to ± 400 V can be achieved in the bridged configuration. In the unipolar mode, the negative output range is fixed at -30V for use with stack actuators.

The PDm200 can drive stack actuators; standard piezoelectric actuators; two wire benders; and three-wire piezoelectric benders requiring a 200V bias voltage.

Compatible Actuators	
Stack Actuators	100V, 120V, 150V, 200V
Plates and Tubes	up to ± 200 V
Two Wire Benders	up to ± 200 V
Three Wire Benders	0 to 200V with 200V bias ± 100 V with ± 100 V bias

The PDm200 is suited to a wide range of applications including: Electro-optics, ultrasound, vibration control, nanopositioning systems, and piezoelectric motors.

The PDm200 is protected against current overload and excessive temperature. The PDm200 can be used as a stand-alone module or mounted to a base with four M2.5 threaded spacers. The PCB mounting version (PDm200-PCB) is supplied with headers for direct mounting on a host motherboard.

Specifications	
Power Supply	± 12 V to +34 V
Max Unipolar Output	-30V to 200 V
Max Bipolar Output	± 200 V (± 400 V bridge mode)
Av. Output Current	46 mA (± 100 V Output)
Power Bandwidth	63 kHz (3.9 nF load, 100 Vp-p)
Peak Output Current	300 mA
Signal Bandwidth	200 kHz
Slew Rate	20 V/us
Dimensions	71 x 38 mm
Weight	50 g
Gain	20 V/V
Input Impedance	200 k Ω
Input Offset	± 10 mV
Load	3.9 nF to 100 uF
Overload	Thermal and current overload protection
Noise	<1 mV RMS (1uF Load)
Environment	-40 to 60°C (-40 to 140°F) Non-condensing humidity
Quiescent Current	100 mA (7.5 mA in Shutdown)

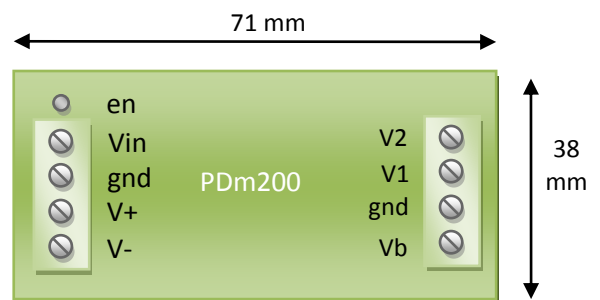

Inputs		Outputs	
en	Enable	V2	Low Noise Output
Vin	Input Signal	V1	High Speed Output
gnd	Ground	gnd	Ground
V+	Positive Supply	Vb	Bias Voltage
V-	Negative Supply		

Figure 1. Connection diagram

Operation

The system block diagram is illustrated in Figure 2. A power converter generates a unipolar or bipolar supply. The output voltage range is controlled by the voltage selector jumpers.

The amplifier has a gain of 20 and an input voltage range of ± 10 V. The load is connected directly to the high-speed output (V1) or through a filter (V2) which reduces the noise and bandwidth. In most applications, the V2 output is recommended.

When the amplifier is configured for 200V operation, a 200V bias supply is enabled for bimorph bender applications.

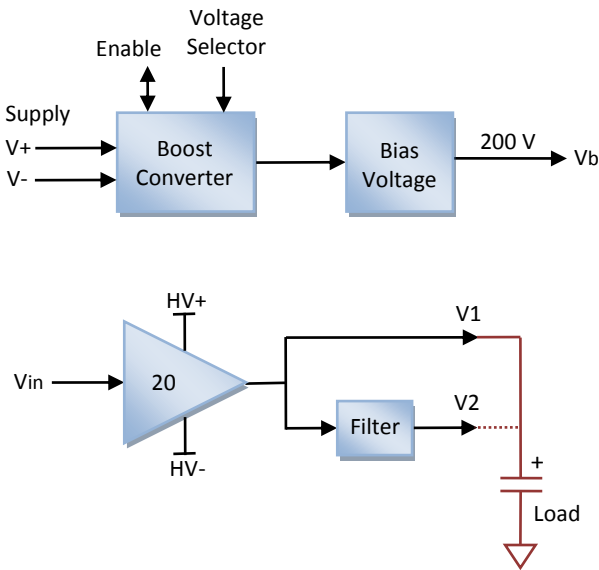

Figure 2. PDM200 Block Diagram

Configuration

The PDM200 is configurable to suit a wide range of power supply and output voltage ranges. The output voltage range is selected by a two jumpers marked L1 and L2, each of which has four possible positions marked by the letters *a* to *d* and *e* to *h*.

In unipolar output mode, the negative output range is fixed at -30 V and the jumper L2 is always in the 'E' position. The correct position for the L1 jumper is listed below for different power supply voltages.

Output Voltage		Power Supply Voltage			
Pos.	Neg.	± 12 to ± 14 V	± 15 to ± 17 V	+24 V* to 30V	+30V* to 34
200 V	-30 V		D		D
150 V	-30 V	D	C	D	C
120 V	-30 V	C	B	C	B
100 V	-30 V	B	A	B	A

Table 1. Unipolar jumper configuration (L2 = E)

*With a single supply, the negative output voltage range is reduced from -30 V to -20 V.

In bipolar output mode, the correct positions for the L1 and L2 jumpers are listed in below in Table 2.

In the ± 200 V mode, a 330 Ω resistor is recommended in series with the output. See the section on "Stability" for more details.

Output Voltage		Power Supply Voltage			
Pos.	Neg.	± 12 to ± 14 V	± 15 to ± 17 V	+24 V to 30V	+30 V to 34
200 V	-200 V		D,H		D,H
150 V	-150 V	D,H	C,G	D,H	C,G
100 V	-100 V	B,F	A,F	B,F	A,F

Table 2. Bipolar jumper configuration

Example Applications

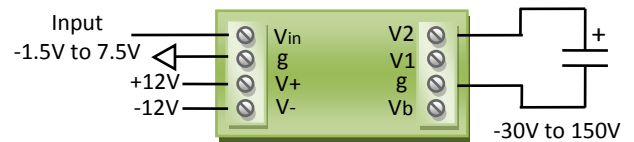

150 V Piezo stack driver

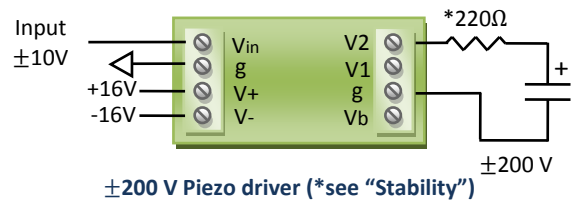

±200 V Piezo driver (*see "Stability")

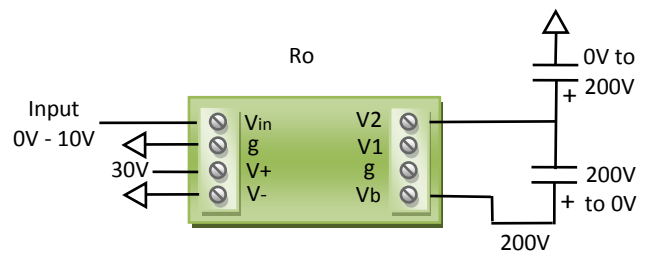

200 V Three-wire bender driver with bias



±100 V Piezo driver

Output Current

The peak output current is approximately 300 mA and the maximum average output current is approximately

$$I_{av} = \frac{0.375 \times V_s}{V_{out}} - 0.01,$$

where V_s is the differential supply voltage e.g. 30V, and V_{out} is the differential output voltage range e.g. 400 V.

The PDm200 calculator can be used to estimate the maximum input and output current for a given supply voltage and output voltage range. Some common values are tabulated below.

Voltage Range	Average Current
-30 V, +150 V	53 mA
-30 V, +200 V	39 mA
-100 V, +100 V	46 mA
-200 V, +200 V	18 mA

Table 3. Average output current for $\pm 15V$ supply

Supply Current

The maximum supply current is 0.5 A at full load. For a partial load, the supply current is

$$I_{in} = \frac{P_{in}}{V_s},$$

where the required input power is

$$P_{in} = 1.33 V_{out}(0.01 + I_{av}),$$

where V_{out} is the differential output voltage range and I_{av} is the average output current.

Heat Dissipation

With a capacitive load, the majority of input power is dissipated as by the amplifier. The worst-case power dissipation is approximately 15 W.

The thermal impedance of the PDm200 from junction to ambient is approximately 10 °C/W in still conditions. An air-flow of 100 LFM or greater is recommended when more than 5 W is dissipated continuously. The PDm200 will shut down when the heat-sink reaches 70 °C

Power Bandwidth

The output slew-rate of the PDm200 is 20 V/us. Therefore, the maximum frequency sine-wave is

$$f_{max} = \frac{20 \times 10^6}{\pi V_{L(p-p)}}$$

The power bandwidth for a range of common sine-wave amplitudes are listed in the following table.

Voltage Range	Power Bandwidth
100 V	63 kHz
200 V	31 kHz
300 V	21 kHz
400 V	15 kHz

Table 4. Unloaded power bandwidth

With a capacitive load, the power bandwidth is limited by the average output current. The maximum frequency sine wave is

$$f_{pwr} = \frac{I_{av}}{V_{L(p-p)} C_L}$$

The power bandwidth for a range of load capacitance values is listed below.

Load (uF)	Peak to Peak Voltage			
	100 V	200 V	300 V	400 V
0.01	63000	19500	9333	4500
0.03	25667	6500	3111	1500
0.1	7700	1950	933	450
0.3	2567	650	311	150
1	770	195	93	45
3	257	65	31	15
10	77.0	19.5	9.3	4.5
30	25.7	6.5	3.1	1.5

Table 5. Power bandwidth for a capacitive load

In the following figures, the maximum peak-to-peak voltage is plotted against frequency for a range of capacitive loads.

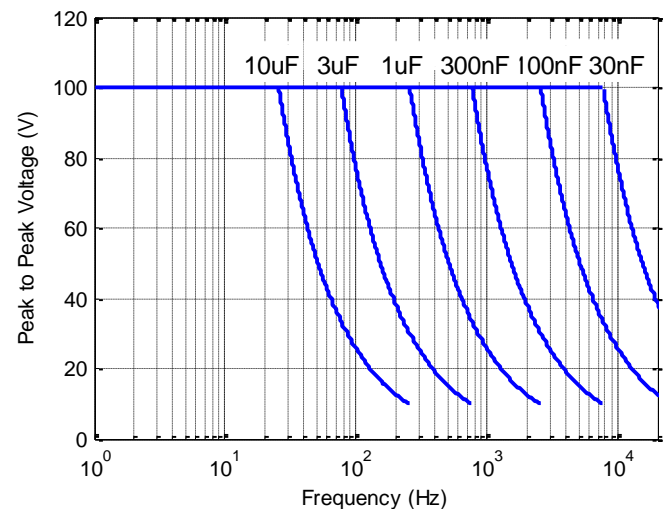

Figure 3. 100 V range power bandwidth

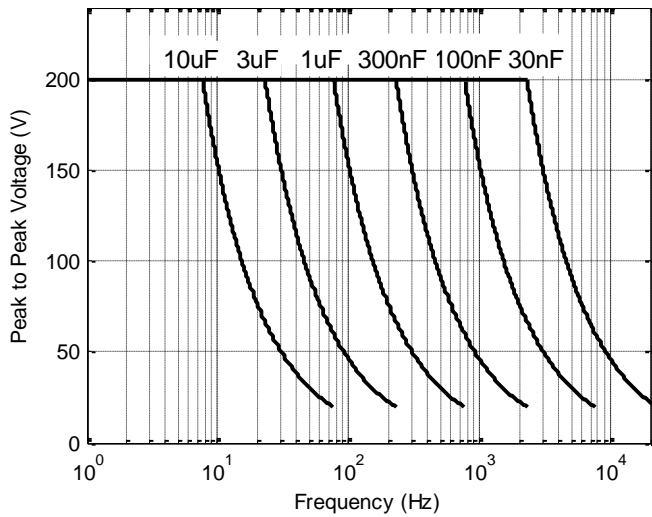

Figure 4. 200 V range power bandwidth

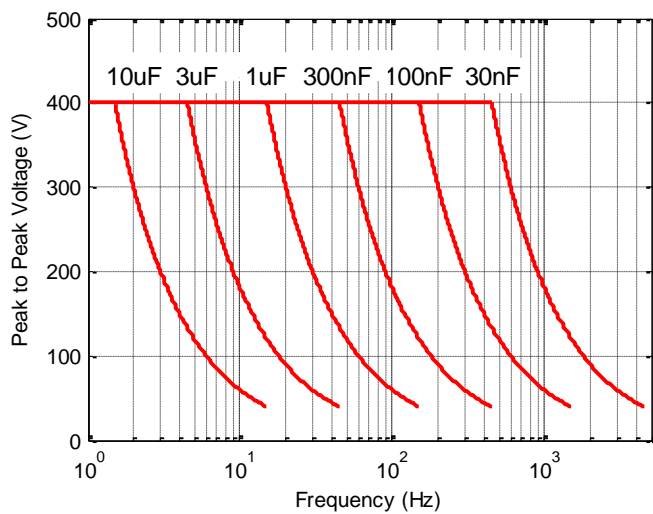

Figure 5. 400 V range power bandwidth

The power bandwidth is primarily related to the average current limit as described above. However, when operating at full range, e.g. ± 200 V, with the minimum supply voltage, e.g. ± 15 V, the power supply droop can distort the top of a signal. This effect can be reduced by increasing the supply voltage. If this is not possible, the full-range power bandwidth should be de-rated by 50%.

Signal Bandwidth

With a load capacitance greater than 100 nF, the small signal bandwidth is

$$f_{bw} = \frac{1}{63 C_L}$$

With a load capacitance less than 100 nF, the small signal bandwidth is approximately 200 kHz.

The bandwidth of the low noise output (V2) is approximately one quarter of the high speed output, that is,

$$f_{bw} = \frac{1}{233 C_L}$$

The small signal bandwidth for a range of capacitive loads is listed in Table 6.

Load Capacitance	High Speed Bandwidth	Low Noise Bandwidth
10 nF	200 kHz	200 kHz
30 nF	200 kHz	140 kHz
100 nF	158 kHz	42 kHz
300 nF	52 kHz	14 kHz
1 uF	15 kHz	4.2 kHz
3 uF	5.2 kHz	1.4 kHz
10 uF	1.5 kHz	430 Hz
30 uF	530 Hz	140 Hz

Table 6. Small signal bandwidth

Noise

The output of the PDM200 contains a small amount of switching noise from the boost converter and random noise from the high-voltage amplifier. With a ± 15 V supply and ± 100 V output range, the RMS noise is listed in Table 7.

For applications requiring low noise, a 220 Ω resistor can be placed in series with the load capacitance. This will reduce the noise by approximately a factor of three. For further noise reduction methods contact info@piezodrive.com

Load Cap	High Speed Output	Low Noise Output
10 nF	4.1 mV*	4.1 mV*
100 nF	1.3 mV*	1.3 mV*
1 uF	1.3 mV	0.72 mV
10 uF	0.42 mV	0.30 mV

Table 7. RMS noise

The noise measurements were performed with the input shorted. The noise may increase when significant current is drawn from the output due to ripple from the boost converter.

*For load capacitances of 100nF or smaller, a 220 Ω resistor is recommended in series with the load.

Stability

The PDM200 is stable with capacitive loads from 3.9 nF to greater than 100 uF. When using the PDM200 as a voltage amplifier with no capacitive load, a 3.9 nF capacitor is required at the output. For this purpose, a

3.9 nF ceramic capacitor (250V, 1206 package) can be mounted at location C33 on the PCB. This capacitor can be installed before delivery if necessary.

If the load capacitance is connected via a long cable, the cable inductance can cause stability problems. To avoid oscillation, a 3.9 nF capacitor should be connected directly to the output as described above.

In the ± 200 V range, oscillation can occur with some load capacitances when the output voltage is very close to the negative rail (-190V). This problem can be eliminated by placing a 220Ω resistor in series with the load capacitance as shown in the example applications. Alternatively, a 330pF 25V 0603 capacitor can be soldered on top of R14 which reduces the bandwidth to approximately 3 kHz and will avoid oscillation. This capacitor can be installed before delivery if necessary.

Bias Output

The bias output (Vb) provides a fixed +200 V output for driving 200 V three-wire actuators like benders that require a bias voltage. Actuators that require a ± 100 V bias can also be driven in this configuration as this is electrically identical.

The bias output can sink or source an average current of 10 mA. However, there is no protection so care must be taken not to exceed the current limit. If more than 10 mA is required, the primary output of a second PDM200 can be used to generate the bias.

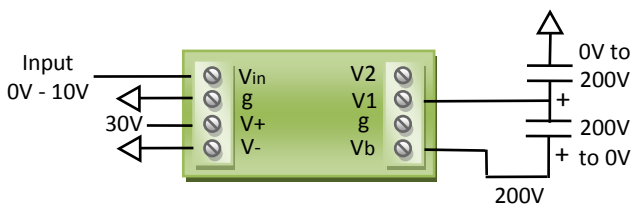

200 V Three-wire bender driver with bias

Enable / Shutdown

The Enable pin is a high impedance signal that floats 5V above the negative supply rail. It can be pulled to the negative supply rail to disable the amplifier. The voltage on this pin can also be monitored to check the status of the amplifier. Any monitoring circuit should have an input impedance of greater than 200 k Ω .

Overload Protection

The PDM200 is protected against over-current and thermal overload. If the PCB temperature exceeds 70 °C the amplifier will be disabled until the temperature reduces.

Bridge Configuration

The output voltage range can be doubled by driving the load in a bridged configuration as shown below. Both amplifiers should be configured for ± 200 V operation.

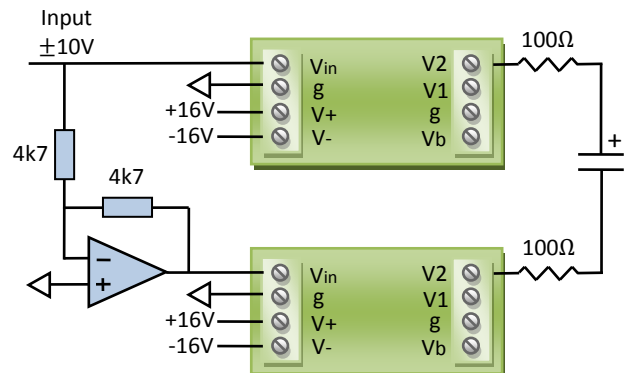

± 400 V Piezo driver

The power bandwidth for this configuration can be calculated by considering only one amplifier and doubling the effective capacitance.

Safety

This device produces hazardous potentials and should be used by suitably qualified personnel. Do not operate the device when there are exposed conductors.



Parts of the circuit will store charge so precautions must also be taken when the device is not powered

Dimensions

The mounting posts accept an M2.5 screw. For the PCB mounting version, a schematic and footprint library is available for Altium Designer, contact info@piezodrive.com to receive the file.

Contact / Support

info@piezodrive.com

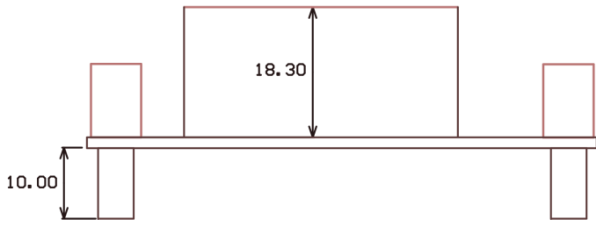
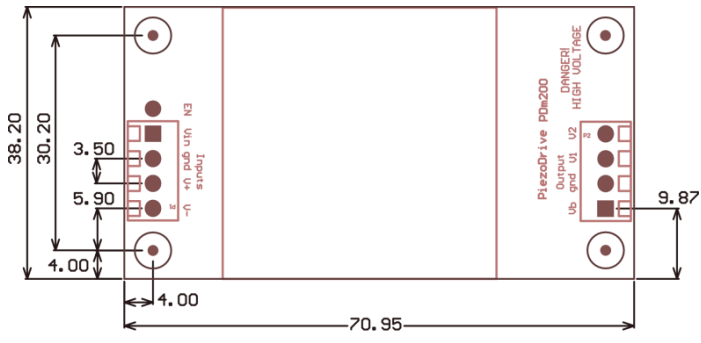

Figure 6, Dimensions (mm)